

MODEL : NEPTUNE FILTRE - 1400

PRODUCT CODE : 021217

FILTRATION AREA : 1,54 m²

FILTER DIAMETER : 1400 mm

VOLUME: 1650 L

FILTRATION MEDIA : 0,4 - 0,8 mm

OPERATION PRESSURE : 2,5 kg/cm²

TEST PRESSURE : 3,5 kg/cm²

FLOW RATE: 77 m³/h

FILTRATION RATE : 50 m³/h/m²

PRODUCT YEAR : 2023

CUSTOMER NAME :

SİPARİŞ NUMARASI:

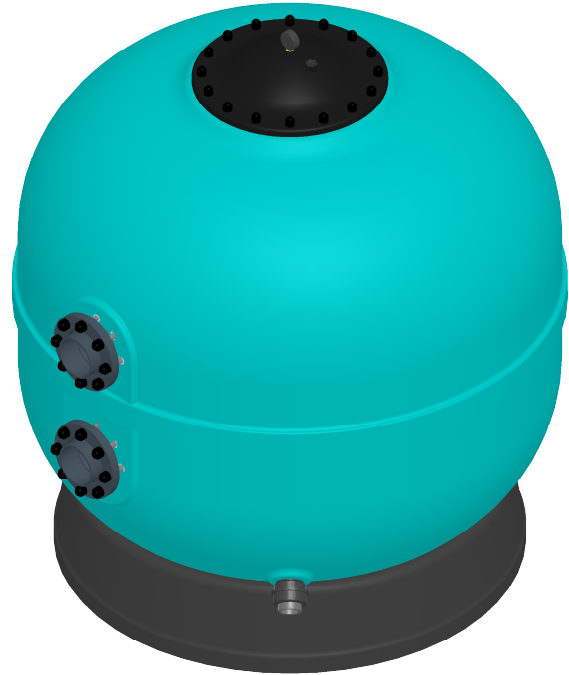
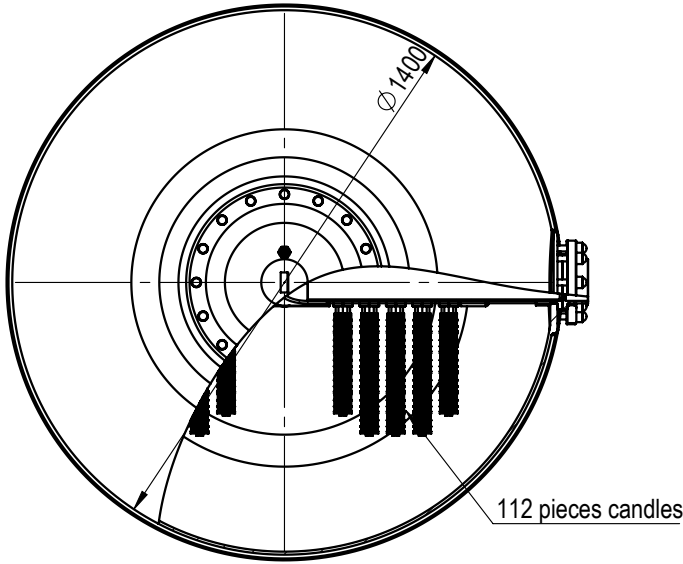
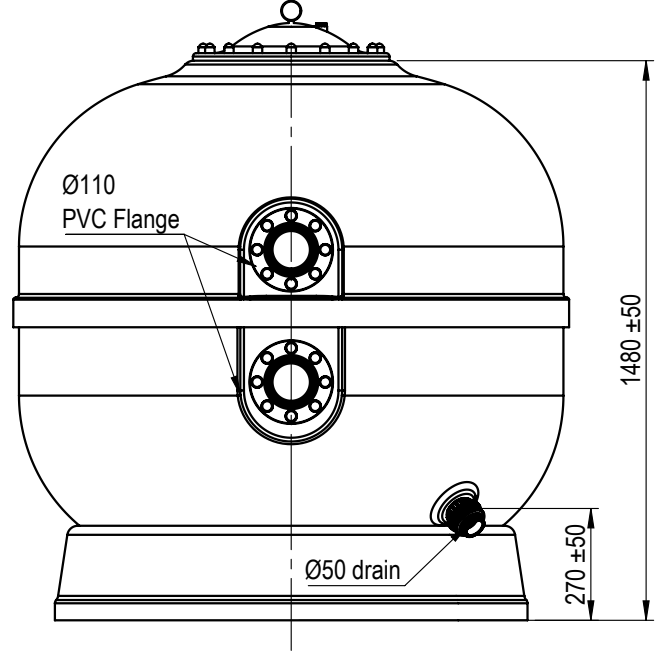
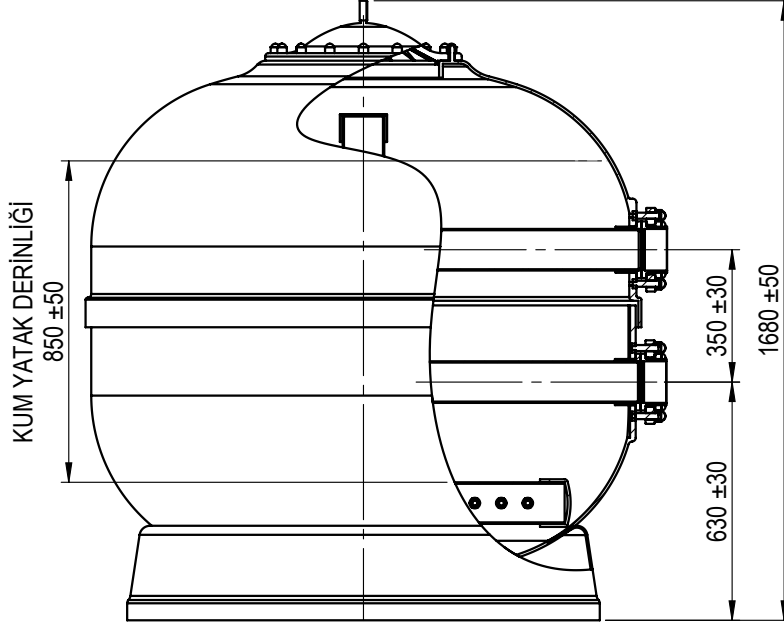

Ölçüler "mm" cinsindedir.

RESİM ÜZERİNDEN ÖLÇÜ ALINMAZ.
DO NOT TAKE THE MEASUREMENT ON THE DRAWING

Rev. No / Rev. No	Rev. Tarihi / Rev. Date	Revizyon Notu / Revision Note	Rev.Ad-Soyad / Rev.Name-Surname	İmza / Signature
Revizyon / Revision	Tarihi / Date	Ad-Soyad / Name-Surname	İmza / Signature	Ağırlık (gr) / Weight (gr)
Çizen / Designed By	28.12.2023	MELTEM KILIÇ		
Kontrol / Checked By		İBRAHİM KAYA		Stok Kodu / Stock.No
Onay / Aproved By		İBRAHİM KAYA		021217
Ölçek / Scale	Parça Adı / Part Name		Form / Form	Malzeme / Metarial
	Ø1400 Neptune Umumi Havuz Kum Filtresi		A4	

